



HAYWARD Hi-Performance above ground SELF-PRIMING PUMPS INSTALLATION AND OPERATING INSTRUCTIONS

Ultra-Pro LX^{SERIES}

Your Hayward Ultra-Pro LX pump has been quality-built and engineered to give you many years of efficient, dependable service. The non-conductive, corrosion-proof motor housing provides protection from the elements and insulates the electrical motor parts from outside contact.

The advanced design reduces operation and maintenance to simple, common-sense procedures.

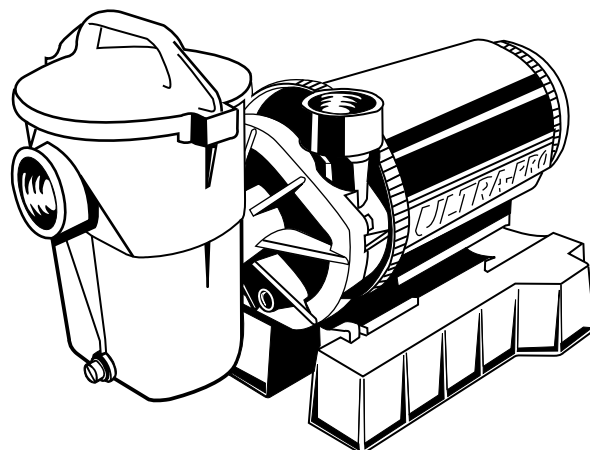

GENERAL TIPS ON PUMP INSTALLATION

For best pump performance, locate the system below the pool water line and as close to the pool as possible. *If you own an above ground pool please see Note: NSPI- 4 Article V, for safe and proper installation of the equipment package.* Make sure suction joints are tight. Suction pipe should be as large or larger than discharge pipe.

Damp, non-ventilated locations should be avoided. Motors require free circulation of air to aid in cooling.

Insure that the electrical supply available agrees with the motor's voltage, phase and cycle, and that wire size is adequate for the HP/KW rating and distance from the power source. Motor must always be properly grounded. If cord connected, use only a properly grounded outlet. Electrical circuits should be protected by proper size ground fault circuit interrupter (GFCI). All electrical wiring should be performed by qualified personnel and must conform to local codes and regulations.

STARTING AND PRIMING INSTRUCTIONS

Fill strainer/housing completely with water. Never operate the pump without water. Water acts as a coolant and lubricant for the mechanical shaft seal.

Open all suction and discharge lines and valves, as well as air bleed (if available) on filter. (The air that is to be displaced from the suction line must have some place to go).

Turn on power and allow a reasonable time for priming. Priming time depends on suction lift and length of suction piping. If pump will not start, or will not prime, see TROUBLE SHOOTING GUIDE on back page.

Note: NSPI-4 Article V, standard for above ground and on ground pools, advises that components such as the filtration system, pumps and heater be positioned so as to prevent their being used as a means of access to the pool by young children.

MAINTENANCE

1. Clean strainer basket regularly. Do not strike basket to clean. Inspect strainer cover gasket regularly and replace as necessary.
2. Hayward pumps have self-lubricating motor bearings and shaft seals. No lubrication is necessary.
3. Keep motor housing clean. Insure air vents are free from obstructions, debris, etc.

4. Occasionally, shaft seals must be replaced, due to wear or damage. See instructions

STORAGE/WINTERIZING

Pump and motor must be protected from freezing. Shut off all electric power. Disconnect cord/electrical connections and plumbing connections. Drain thoroughly and clean out any debris. Store pump and motor in a dry, well ventilated room.

HAYWARD POOL PRODUCTS CANADA, INC.

2880 PLYMOUTH DRIVE, OAKVILLE, ONTARIO L6H 5R4 • (905) 829-2880

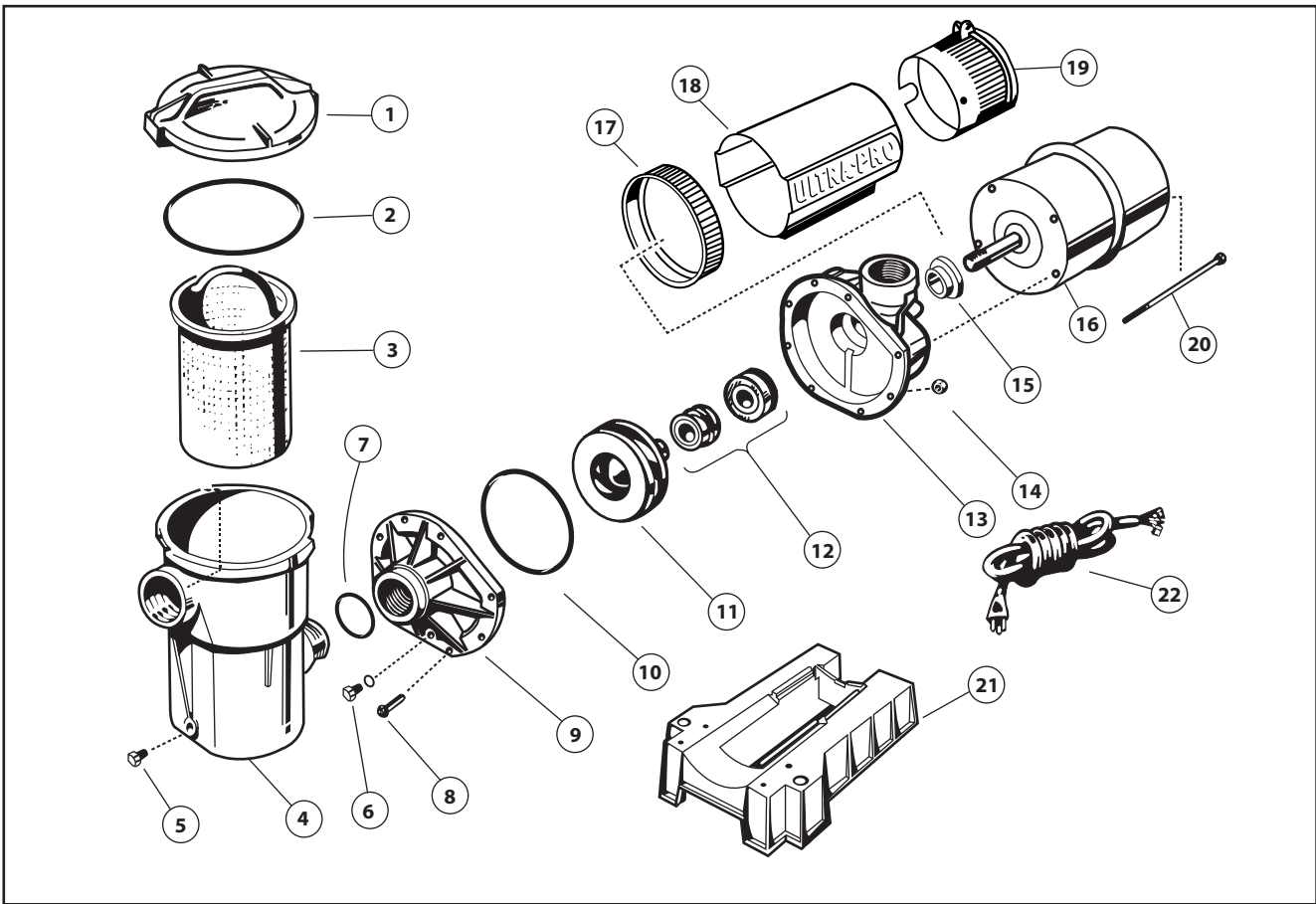

Ref No.	DESCRIPTION	No. Req'd	PART NUMBER	
			MODEL SP2290 (ET)	MODEL SP-2295 (ET)
1	Strainer Cover	1	SP1680E	SP1680E
2	Strainer Cover w/o-ring	1	SP1500P	SP1500P
3	Basket	1	SP1500LX	SP1500LX
4	Strainer Housing	1	SP1500CP	SP1500CP
5	Drain Plug (optional)	--	SP1700FG	SP1700FG
6	Drain Plug w/Gasket	1	SP1700FG	SP1700FG
7	O-ring	1	SP1500W	SP1500W
8	Bolt, No. 10-24 Hex. Head	8	SP1500N2	SP1500N2
9	Housing Cover	1	SP1580BP	SP1580BP
10	Housing O-ring	1	SP1580Z1	SP1580Z1
11	Impeller	1	SP1500E	SP1500F
12	Seal Assembly	1	SP1500KA	SP1500KA
13	Pump Housing	1	SP1580AAP	SP1580AAP
14	Nut, No. 10-24 Hex	8	SP1500Y2	SP1500Y2
15	Shaft Sleeve	1	SP1500Q5	SP1500Q5
16	Motor	1	SP1509ZIUF	SP1514ZIUF
17	Shroud	1	SP2090B	SP2090B
18	Motor Housing	1	SP2090A	SP2090A
19	Motor End Cover	1	SP2090CAM	SP2090CAM
19b	Timer End Cover (Electronic) (ET)	Optional	SP2090CETM	SP2090CETM
20	Motor-To-Housing bolt	4	To order, specify manufacturer, HP and Model No.	
21	Elevated Mounting Base	1	SP2601C	SP2601C
22	Power Cord	1	SP1550WA7C	SP1550WA7C

ELECTRONIC TIMER MODULE INSTRUCTIONS

Your integrated timer module is designed to be programmed to your filtration need, with four (4) possible settings.

TO SET TIMER

1. Move switch "OFF" to "PROGRAM" back to "OFF" - resulting single tone indicates Setting #1. Repeat until number of tones heard equals setting desired. ie 3 rapid tones is Setting #3
2. Move switch from "OFF" to "RUN": to begin selected program setting.

TWO SPEED MOTOR SETTINGS

- Setting 1 - Pump runs 24 hours on Hi Speed (single tone)
Setting 2 - Pump runs 18 hours on Hi, 6 hours on Low (2 tones)
Setting 3 - Pump runs 12 hours on Hi, 12 hours on Low (3 tones)
Setting 4 - Pump runs 6 hours on Hi, 18 hours on Low (4 tones)

SINGLE SPEED MOTOR SETTINGS

- Setting 1 - Pump runs 24 hours Continuous (single tone)
Setting 2 - Pump runs 18 hours, off 6 hours (2 tones)
Setting 3 - Pump runs 12 hours, off 12 hours (3 tones)
Setting 4 - Pump runs 6 hours, off 18 hours (4 tones)

TO OVERRIDE TIMER SETTINGS

- Move switch from "RUN" to "OFF" and back to "RUN" within 3 seconds.
The pump will run for 1 hour and then return to the previous programmed setting.
If a power failure occurs the timer automatically returns to the programmed setting.

SEAL CHANGE INSTRUCTIONS

*Exercise extreme care in handling and installing the new seal and seat assembly.
The lapped and polished surfaces may easily be damaged by dirt or scratching.*

For safety, all service must be performed with all power shut off.

01. Turn off power and unplug power cord. Remove pump and motor assembly from piping system. (If optional elevated mounting base was installed, pump assembly can be disengaged from elevated base by depressing spring catch on top of base, and sliding pump assembly out to the rear).
02. Remove motor housing end cover by removing two (2) screws. Carefully pull cover away from motor and disconnect wires from motor terminals.
03. Remove pump housing cover (with strainer attached) by removing the eight (8) housing bolts and nuts which fasten housing cover to pump housing. The impeller is now exposed.
04. To remove impeller, insert screwdriver in slot at end of motor.* Hold screwdriver so as to keep shaft from turning, and rotate the impeller in a counterclockwise direction. The spring portion of the seal assembly is now exposed.
05. Note carefully the position of the spring seal and pull it off the impeller.
06. To remove the stationary (ceramic seat) part of the seal assembly:
 - a. Loosen the four (4) motor securing bolts and disengage the motor, with motor housing in place, from the pump housing.
 - b. With motor removed, press the clear plastic and ceramic seat assembly out of the pump housing recess. If tight, tap lightly from the "motor" side.
07. Clean and lubricate the impeller hub shaft and pump housing seal recess. Use silicone or Jack's No. 327 O-Ring lube. Gently wipe the polished face of the new ceramic seat with a soft, dry cotton cloth.
08. Press the new spring portion of the assembly onto the impeller, black polished surface facing away from the impeller.
09. Be sure black rubber O-Ring is in place on cut ridge of clear plastic seat retainer. Press plastic retainer, with ceramic seat inside, into recess of pump housing - O-Ring end first. Seat the assembly firmly and evenly, using finger pressure.
10. Carefully insert the motor shaft thru the seat assembly, and secure motor and motor housing to pump housing with four (4) motor securing bolts. (Be sure motor housing mounting bracket is positioned properly).
11. Screw the impeller, with spring seal, onto the motor shaft, hand tight, by turning clockwise.
12. Clean housing O-Ring (replace if necessary) and fasten housing cover to pump housing with eight (8) bolts and nuts. Tighten bolts and nuts alternately and evenly.
13. Reconnect electric wires from power cord and timer to pump motor terminals. Both white wires to line 2; both black wires to A; red timer wire to line 1. Ground wire to ground screw on motor. Replace cover and secure with two (2) screws.
14. Reconnect pump to piping system. Be sure to fill strainer with water before restarting.

ELECTRICAL GUIDE – 60 CYCLE MOTORS – SINGLE PHASE

MOTOR		VOLTS	Circuit Breaker RATING - AMPS	RECOMMENDED WIRE SIZE 0-50', 0-15m
HP	KW			
1	.75	115	20	No. 12
1 1/2	1.12	115	20	No. 12

TROUBLE SHOOTING GUIDE

A. MOTOR WON'T START

1. Check for improper or loose connections, open switches or relays, blown circuit breakers or fuses.
2. Manually check rotation of motor shaft for free movement and lack of obstruction.

B. MOTOR CUTS OUT – Check for:

1. Wiring, loose connections, etc.
2. Low voltage at motor (frequently caused by undersized wiring).
3. Binding and overload. (Amperage reading)

NOTE: Your Hayward pump motor is equipped with Automatic Thermal Overload Protection. The motor will automatically shut off, under normal conditions, before heat damage build-up, due to an improper operating condition, can occur. The motor will auto-restart when safe heat level is reached.

C. MOTOR HUMS BUT DOES NOT START

– Check for:

1. Centrifugal switch stuck in open position.
2. Binding of motor shaft.

D. PUMP WON'T PRIME

1. Make sure pump/strainer housing is filled with water, and that cover O-Ring is clean and properly seated. Make sure strainer cover is locked firmly in position.
2. Make sure all suction and discharge valves are open and unobstructed, and that pool water level is above all suction openings.

3. If pump develops a vacuum, check for blocked suction line or strainer, or air leak in suction piping.
4. If pump does not develop a vacuum and pump has sufficient "priming water":
 - a. Tighten all bolts and fittings.
 - b. Check voltage to make sure pump is up to speed.
 - c. Open pump and check for clogging and obstruction.
 - d. Remove and replace shaft seal.

E. LOW FLOW – Generally, Check for:

1. Clogged or restricted strainer or suction line; undersized pool piping.
2. Plugged or restricted discharge line of filter (high discharge gauge reading).
3. Air leak in suction (bubbles issuing from return fittings).
4. Pump operating underspeed (low voltage).
5. Plugged or restricted impeller.

F. NOISY PUMP – Check for:

1. Air leak in suction causing rumbling in pump.
2. Cavitation due to restricted or undersized suction line and unrestricted discharge lines. Correct suction condition or throttle discharge lines, if practical.
3. Vibration due to improper mounting, etc.
4. Foreign matter in pump housing.
5. Motor bearings made unserviceable by wear, rust, or continual overheating.

SERVICE AND REPAIRS

Consult your local authorized Hayward dealer or service center.
No pumps or motors may be returned directly to the factory without the express written authorization of Hayward Pool Products Canada, Inc.